

Typical Applications

- GPS Receivers
- Galileo Receivers
- GLONASS Receivers
- L1 and L2 Dual Band Receivers

Key Features

- Adjustable Gain (16/10dB)
- L1 and L2 Band Operation
- -2/+3dBm Input IP3
- 2.7V to 3.0V Supply

Block Diagram

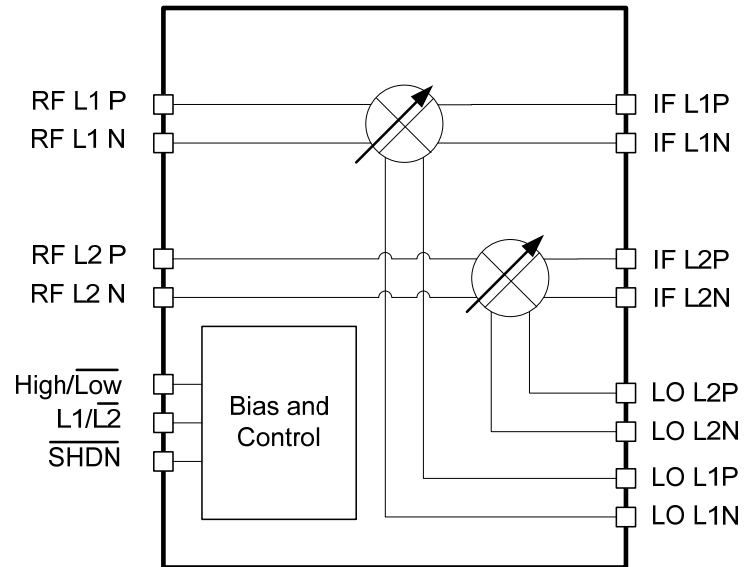

IP Block Overview

The TRFS10004 is a dual mixer core designed for positioning receivers. It operates from a 2.7V to 3.0V supply and features dual inputs intended to downconvert L1 (1575.42MHz) and L2 (1227.6MHz). While optimized for this frequency range, the IP block can be adapted to accommodate different RF frequencies through external matching changes or chip modifications. Each mixer also features adjustable gain between 16dB in high gain mode and 10dB low gain mode. Each mode can be selected with a digital control signal which can be driven by a processor or by Tahoe RF's IF level detector circuitry. An electronically controlled shutdown mode allows this IP block to be turned off completely using a digital control signal.

IP Block Performance Summary

Specification	Conditions	MIN	TYP	MAX	Units
Temperature Range		-40	25	85	°C
VDD		2.7	3.3	3.0	V
IDD	High Gain or Low Gain		12		mA
IDD	Shutdown Mode			100	μA
RF Input	L1		1575.42		MHz
RF Input	L2		1227.6		MHz
Input IP3	High Gain Mode		-2		dBm
	Low Gain Mode		3		
Gain	High Gain Mode		16		dB
	Low Gain Mode		10		
Noise Figure	High Gain Mode		10		dB
	Low Gain Mode		12.5		
LO Feedthrough	Fundamental		60		dB
	2 nd Harmonic		70		
LO Input Drive			tbd		mVp

Known Limitations/Issues

Revision History

Revision #	Date	Notes
V1.0	10-Dec-2008	Initial Draft
V1.1	14-Jan-2009	Initial Customer Release