

Typical Applications

- Cellular Phone Transmitters
- Industrial Scientific Medical Transmitters
- Microwave Links
- Cellular Basestations
- Femtocells

Key Features

- Better than -164dBm/Hz noise at 20MHz offset
- Draws Only 7mA @ 3V
- -4dBm Output Power
- BB Bandwidth >30MHz
- 2.0V to 3.6V Supply

Block Diagram

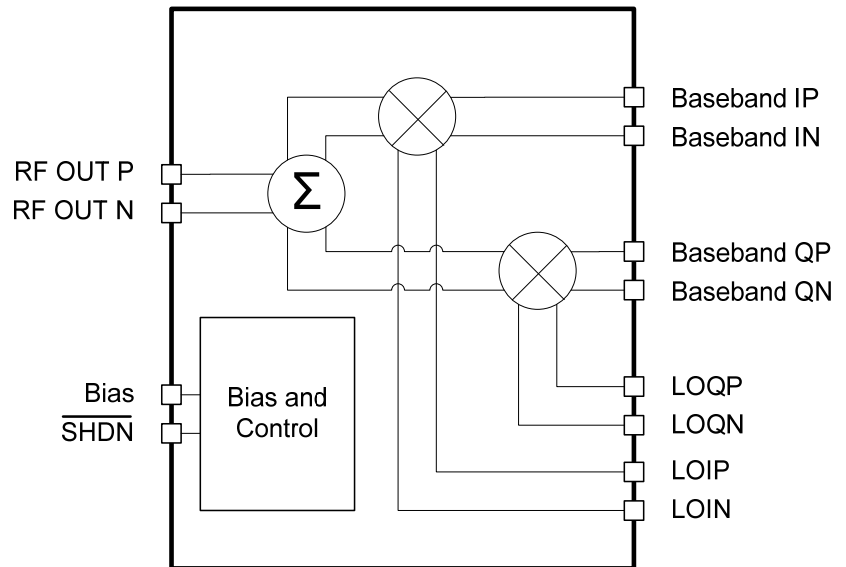

IP Block Overview

The TRFS10005 is a Vector Modulator designed for applications requiring low power consumption and excellent out-of-band noise characteristics. This IP block consists of a pair of mixers with differential inputs, differential In-Phase and Quadrature Baseband Inputs, and a differential RF output. It also includes digital control of bias, including a CMOS-logic compatible shutdown mode. The 0.1dB bandwidth of the baseband input exceeds 25MHz. This allows use in applications where the I/Q inputs are either very wideband or modulated on a carrier. The low output noise reduces filtering requirements and eliminates the need for external SAW filters in many applications.

IP Block Performance Summary

Specification		Conditions	MIN	TYP	MAX	Units
Temperature Range			-40	25	85	°C
VDD			2.0	3.3	3.6	V
IDD				6.5	9	mA
Common Mode Voltage	2.0<vcc<2.4			1.2		V
	2.4<vcc<2.7		1.2	1.3	1.4	V
	2.7<vcc<3.6		1.2	1.4	1.65	V
LO Input Drive			200		320	mVp
RF Bandwidth				824-915		MHz
RF Gain Flatness	center to edge			1.0		dB
	any 5MHz BW			<0.1		dB
Modulation Bandwidth			>30			MHz
Output Power			-6	-4		dBm
Carrier Suppression			30	45		dBc
Output Noise Floor				-165		dBm/Hz

Known Limitations/Issues

Revision History

Revision #	Date	Notes
V1.0	10-Dec-2008	Initial Draft
V1.1	14-Jan-2009	Initial Customer Release