

### Typical Applications

The TRFS-101 is a mixer core circuit for use in such applications as::

- CDMA2000, AMPS, US PCS High Band, US PCS Low Band, Korean PCS, JTACS, TACS Systems
- Dual-mode and multi-band applications
- Voice and data applications

### Product Overview

The TRFS-101 Dual RF Mixer contains two up-conversion mixers for multi-band wireless communication applications at 900MHz and 1.9GHz. The hybrid multi-tanh architecture utilized for the mixer provides high linearity and improved noise characteristics. An active poly-phase filter is incorporated into the mixer to achieve image suppression, thereby eliminating the need for an external image-reject SAW filter. This core circuitry can be easily integrated with other circuits as well as packaged individually in a leadless chip carrier.

### Block Diagram

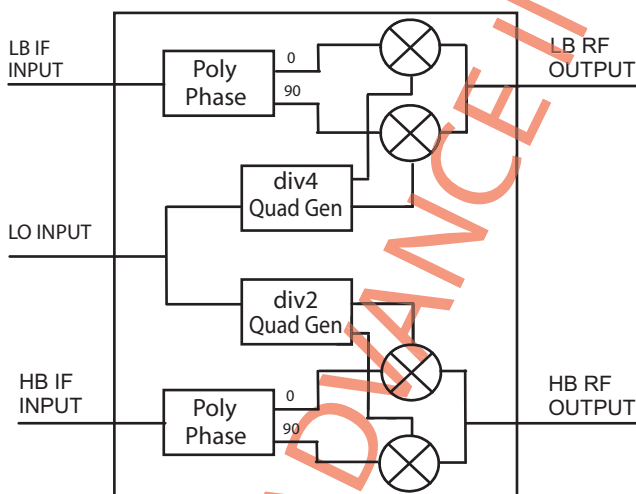

### Key Features

- Multi-band up-conversion to 750-1000MHz and 1.75-2.0GHz
- Multi-tanh architecture
- Nominal output noise floor of 10nV/ $\sqrt{\text{Hz}}$  @40MHz offset
- Nominal OIP3 of 6dBV @-17dBV input
- Internal active poly-phase filters provide image suppression of 60dB

## Performance Summary

Item	Unit	Min	Typical	Max	Notes
Supply Voltage	V	2.7	3.0	3.3	
<b>Low Band</b>					
Operating Frequency	MHz	750		1000	
Conversion Gain	dB		3.5		@750MHz
	dB		2.5		@1GHz
Output Referred Noise @40MHz offset	nV/ $\sqrt{\text{Hz}}$		10		@750MHz
	nV/ $\sqrt{\text{Hz}}$		10		@1GHz
LO-RF Isolation	dB		106		
LO-IF Isolation	dB	>90			
RF-IF Isolation	dB		60		
Image Suppression	dB		80		
OIP3	dBV		5.5		@750MHz, Pin=-17dBV
	dBV		6.5		@1GHz, Pin=-17dBV
Supply Current	mA		7.0		
<b>High Band</b>					
Operating Frequency	GHz	1.75		2.0	
Conversion Gain	dB		2		@1.75GHz
	dB		1.5		@1.91GHz
Output Referred Noise @40MHz offset	nV/ $\sqrt{\text{Hz}}$		9		@1.75GHz
	nV/ $\sqrt{\text{Hz}}$		9		@1.91GHz
LO-RF Isolation	dB		75		
LO-IF Isolation	dB	>90			
RF-IF Isolation	dB		59		
Image Suppression	dB		69		
OIP3	dBV		6		@1.75GHz, Pin=-17dBV
	dBV		6		@1.91GHz, Pin=-17dBV
Supply Current	mA		8		

ADVANCE INFORMATION

**Contact: [sales@tahoerf.com](mailto:sales@tahoerf.com)**  
**Tahoe RF Semiconductor, Inc.**  
**12834 Earhart Ave**  
**Auburn, CA 95602**  
**<http://www.tahoerf.com>**  
**(530) 823-9786**