



Typical Applications

The TRFS-152 is a Receiver for use in such applications as:

- WCDMA Systems
- UMTS Systems

Product Overview

TRFS-152 WCDMA RECEIVER is a direct conversion front-end receiver for WCDMA applications. The receiver incorporates a low noise amplifier (LNA), a dual-gain RF variable gain amplifier (RF VGA), two I/Q down conversion mixers, two base band variable gain amplifiers (BB VGA) and an I/Q quadrature generator. A single-ended-to-differential SAW filter, and a load inductor and bias set resistor for the LNA are the only required off-chip components. The design, including the SAW filter, has a very low value of DC offset at the output of the mixers, and low local oscillator leakage due to high LO-RF isolation. The chip has low overall noise figure, high linearity and very low amplitude and phase mismatch in the I/Q channels. The core can be easily packaged in a leadless chip carrier.

Key Features

- Compatible with WCDMA standard
- Good LO-RF isolation of -105dBm
- Low overall noise figure of 4.3dB
- High linearity with overall IIP2 of 36.6dBm and overall IIP3 of 16dBm
- LO induced DC offset of <1.9mV at output of BB VGA
- I/Q phase mismatch <1° and magnitude mismatch <0.09dB

Performance Summary

Chip Performance (with SAW filter)	Units	Typical
Cascaded Maximum Voltage Gain	dB	45.7
Cascaded Minimum Voltage Gain	dB	8.7
LO Leakage (at output of LNA)	dBm	-105
Cascaded IIP2 (max gain, in-band signals)	dBm	36.6
Cascaded IIP3 (max gain, in-band signals)	dBm	-16.5
P1dB (max gain; in-band)	dBm	-26.3
Cascaded DSB Noise Figure (max gain)	dB	4.3
LO Induced DC Offset @ Mixer output	mV	<0.3
LO Induced DC Offset @BBVGA output	mV	<1.9
Total Supply Current	mA	24.9
Power Supply Voltage	V	2.85
Input Return Loss	dB	<-11
Total Gain Control Range	dB	37
Chip Area	mm ²	5.85

Block Diagram

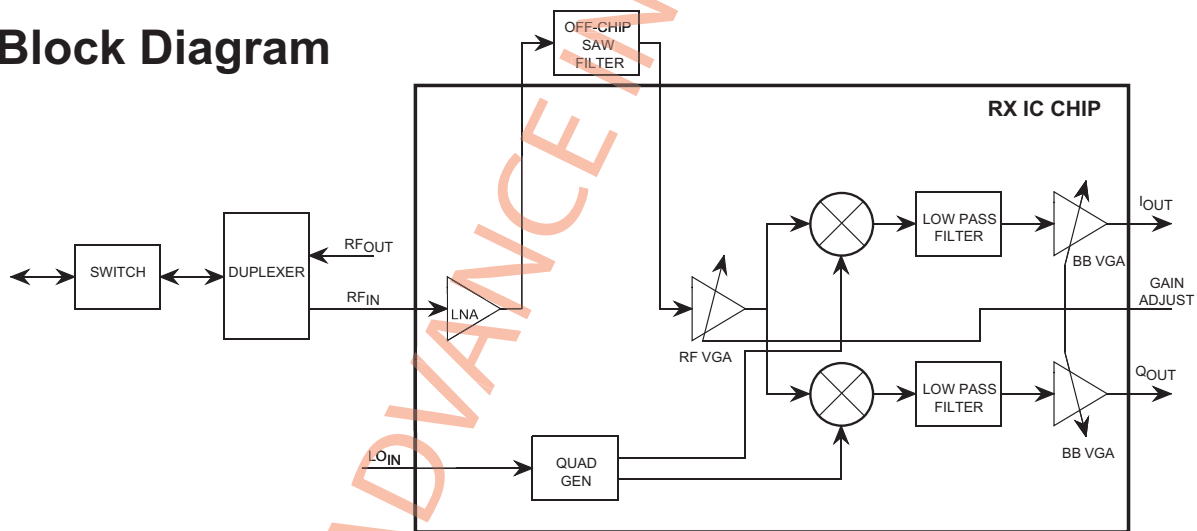

Contact: sales@tahoerf.com
Tahoe RF Semiconductor, Inc.
12834 Earhart Ave
Auburn, CA 95602
<http://www.tahoerf.com>
(530) 823-9786