

Typical Applications

Target applications are products using the GSM, CDMA, WLAN, GPS, PCS/DCS and AMPS wireless communication standards.

- Local Oscillator for down-conversion and up-conversion
- CDMA and GSM cellular phones, Bluetooth

Product Overview

The TRFS-201 is a low-power, fully integrated Voltage Controlled Oscillator operating a nominal frequency of 3.2GHz. A differential architecture improves noise immunity and reduces spurious signal levels from adjacent circuits. The design is intended for use in power sensitive mobile applications. The circuit's low phase-noise makes it suitable for most applications. The core circuitry has a footprint of approximately 600uM x 600uM and can be easily integrated with other circuitry.

Pinout and Block Diagram

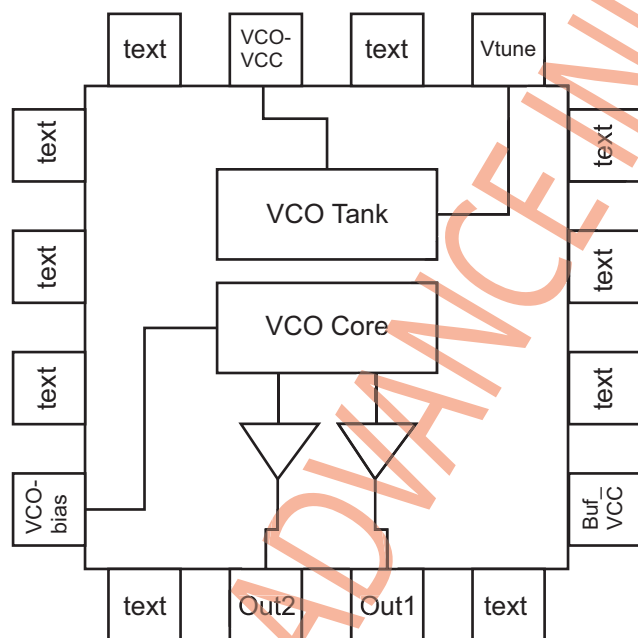

VCO Die Photograph

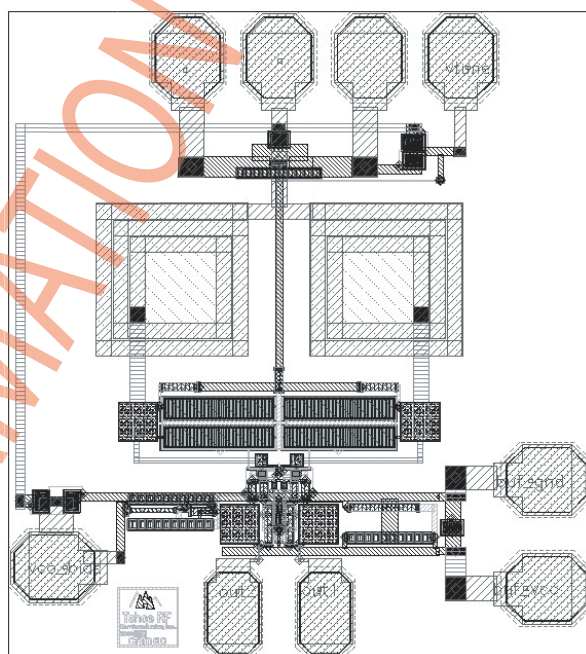

Key Features

- Fully integrated, no external components
- Fully Differential design
- Low power consumption
- Low phase-noise

Contact: sales@tahoerf.com
Tahoe RF Semiconductor, Inc.
12834 Earhart Ave
Auburn, CA 95602
<http://www.tahoerf.com>

Detailed Circuit Description

The TRFS-201 VCO is a differential CMOS oscillator. The design incorporates varactor diodes as tuning elements and is configured to provide a positive tuning slope. The design also includes additional circuitry to help isolate the tank from its supply and therefore reduce susceptibility to pushing effects. The circuit utilizes a small signal swing coupled into output buffers to improve isolation from load pull effects. A differential architecture improves the rejection of external noise and spurious signals that could corrupt signal integrity. The circuit also utilizes local bias circuitry to reduce noise and make the circuit completely self contained. Low current consumption makes this design applicable for use in battery operated systems.

Pin #	Pin Name	Purpose and Usage
1	Vtune	Analog input used to adjust the output frequency
2	NC	
3	VCO_VCC	Power connection for the VCO core
4	NC	
5	NC	
6	NC	
7	NC	
8	VCO_bias	Analog input to set the core operating point/current
9	NC	
10	Out2	Buffered output from the VCO, half of differential signal
12	Out1	Buffered output from the VCO, half of differential signal
13	N/C	No connection
14	Buf_VCC	Power connection for buffers
15	NC	
16	NC	

Parameter	Expected Min	Typ Value	Expected Max	Units
VCO center frequency	3.1	3.2	3.3	GHz
Vtune range	0.500		2.5	V
Kv		125	Kv	MHz/V
Tuning Bandwidth		50		MHz
SSB Phase-Noise @ 1MHz offset		-125		dBc/Hz
Operating Temperature	-25	25	+85	degC
VCC Operating Voltage	2.7	3.0	3.3	V
VCO low frequency		Expected Value		
Kv		175		MHz/V
SSB P-N @ 1MHz offset		123		dBc/Hz
Icore		5		mA DC
Isupply		8		mA DC
VCO mid frequency				
Kv		125		MHz/V
SSB P-N @ 1MHz offset		125		dBc/Hz
Icore		5		mA DC