

Typical Applications

Target applications are products directed to the GSM, CDMA, WLAN, GPS, PCS/DCS and AMPS wireless communication markets.

- Local Oscillator for down-conversion and up-conversion
- CDMA and GSM cellular phones and Bluetooth applications

Product Overview

The TRFS-251 is a low-power, fully-integrated RF Voltage Controlled Oscillator with an accompanying Phase Locked Loop and Synthesizer. The circuitry can be integrated with other transmit or receive signal path circuits to form a fully integrated radio. The TRFS-251 integrates all the circuitry necessary for RF LO generation, including a VCO (with fully integrated tank), an integer-N dual-modulus prescaler, phase detection and charge pump circuitry, lock detect circuitry, and a serial interface control circuitry (PLL loop filter circuitry is implemented off-chip). The circuitry has a footprint of approximately 1.5 mm x 1.5 mm.

Key Features

- Fully integrated. Only the PLL loop filter components are off chip.
- VCO, Buffer and Prescaler circuitry are fully differential.
- Dual-modulus operation for flexible frequency synthesis.
- Low phase noise.
- Low power consumption.

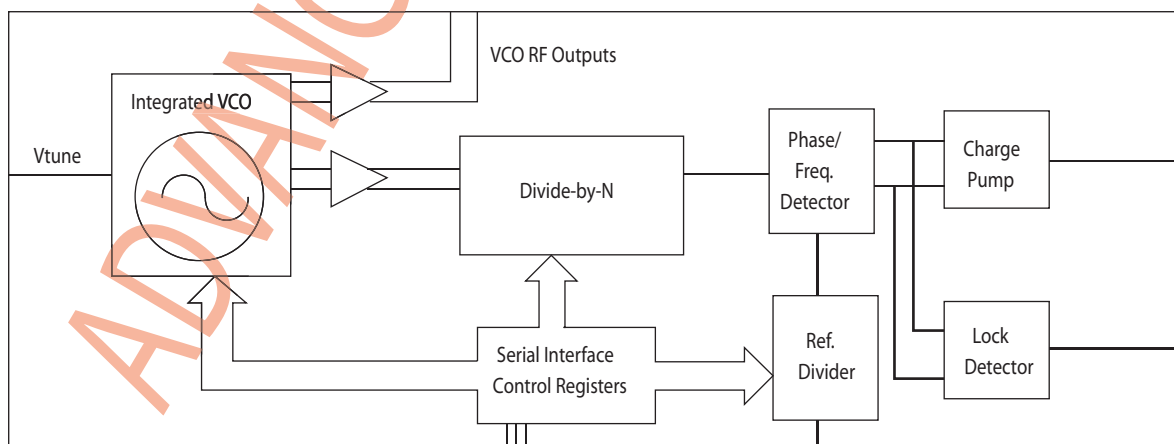

Detailed Circuit Description

The TRFS-251 is a fully integrated VCO and Synthesizer. All tank circuitry is integrated and the oscillator is differential. The VCO design also includes circuitry to help isolate the tank from supply-coupled pushing effects. The dual-modulus integer-N prescaler circuitry is a differential, low noise, low power implementation. The Phase Detector reference input is designed to allow high frequency signal inputs. Charge Pump circuitry incorporates an architecture to produce the lowest possible supply current. A Lock Detection circuit is integrated to provide positive indication of PLL lock condition. Local bias circuitry ensures independent, robust operation over a variety of operating conditions. Integrated serial control circuitry provides flexible, power-efficient operational control.

Parameter	Min Value	Typ Value	Max Value	Units
Operating Temperature	-25	25	+85	degC
Power Supply Voltage	2.7	3.0	3.3	V
VCO Operating Frequency	3.1		3.5	GHz
VCO SSB Phase Noise @ 1MHz offset			-120	dBc/Hz
PLL Reference Input Frequency			50	MHz
VCO RF Output Buffer Signal Swing		200		mV differential
Supply Current (in lock)		10		mA

Contact: sales@tahoerf.com
Tahoe RF Semiconductor, Inc.
12834 Earhart Ave
Auburn, CA 95602
<http://www.tahoerf.com>