

Typical Applications

- GPS Receiver
- Galileo Receiver
- GLONASS Receiver
- L1 and L2 Dual Band Receiver

Key Features

- High Dynamic Range
 - -17 dBm IIP3
 - 12 bit ADC (>60 dB)
- < 0.3W in Low Dynamic Mode
- < 1W in High Dynamic Mode

Block Diagram

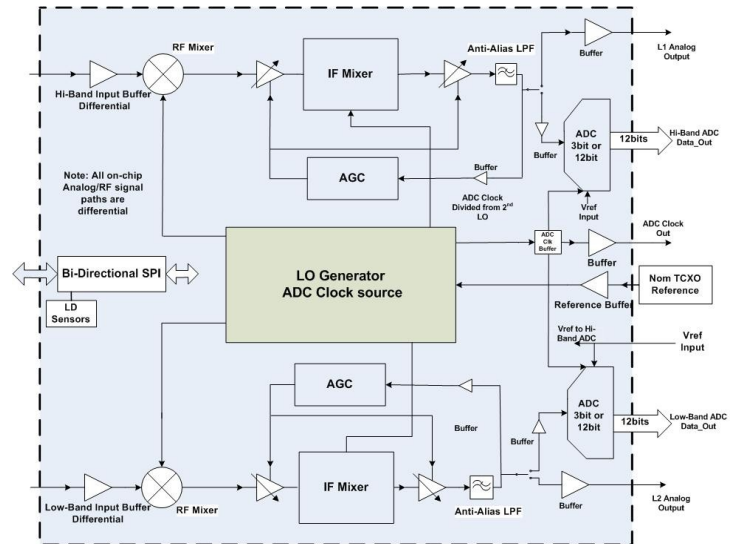

Integrated Circuit Overview

This GPS Receiver chip integrates the bulk of a receive chain for both L1 and L2 GPS bands. Each of the paths amplifies the applied signal, and performs down conversion to a low intermediate frequency. Each signal path band-pass filters the resulting signal. The ADCs have a selectable high resolution mode and a low resolution, low power mode. The low resolution mode has reduced-current and lower linearity. The on chip ADC's can be bypassed by using the analog buffers. Dual fractional-N synthesizers with a shared reference generate RF LO signals. A 3-wire SPI digital interface is used to program and control the functionality of the chip.

Integrated Circuit Performance

Mode	Parameter	Conditions	Min	Typ.	Max	Units	
	Operating Voltage		3.0		3.6	V	
	Operating Temp		-40		85	°C	
High Dynamic Range Mode	Maximum Gain			75		dB	
	Minimum Gain			35		dB	
	Noise Figure	min gain			19		dB
		max gain			6		dB
	Input VSWR				1.5:1		
	Input IP3			-17		dBm	
	PLL Jitter	1kHz to 30MHz BW		4		pSec	
	VCO Phase Noise	Open loop, 10 MHz offset		-140		dBc/Hz	
Power	2-channel operation		700		mW		
Low Dynamic Range Mode	Maximum Gain			75		dB	
	Minimum Gain			35		dB	
	Noise Figure	max gain		6		dB	
	Input VSWR				1.5:1		
	Input IP3			-31		dBm	
	PLL Jitter	1kHz to 30MHz BW		4		pS	
	VCO Phase Noise	Open loop, 10 MHz offset		-140		dBc/Hz	
	Power	2-channel operation		250		mW	

About Tahoe RF

Tahoe RF Semiconductor Inc. is the industry's leading custom IC solutions provider for high performance RF/Analog IC marketplace. Tahoe RF specializes in developing innovative fully integrated RF systems on a chip. Tahoe RF responsibility begins with formalizing the high level customer requirements and ends with the lifetime delivery of fully tested production ICs.